

2S ARCHITECTURAL GLASS SEMINAR

18th November 2011 Prince Hotel Kuala Lumpur

**GETTING THE MOST FROM DAYLIGHT
THROUGH OPTIMISING THE WINDOW DESIGN**



**BENEFIT OF 2S FOR
OUR MOTHER NATURE**
18TH NOVEMBER 2011, FRIDAY
PRINCE HOTEL & RESIDENCE KUALA LUMPUR

Ar Chan Seong Aun
M Arch (Distinction), B Arch (Hons), B Bdg Sc (VUW, NZ), APAM, AIPDM, TAM



CONTENT

- 1. ENERGY EFFICIENT ARCHITECTURE**
- 2. HEAT GAINS THROUGH WINDOWS**
- 3. DAYLIGHTING ESSENTIALS**
- 4. OPTIMIZING THE BUILDING ENVELOPE FROM
DAYLIGHT**

Optimizing Window functions

HEAT GAIN vs DAYLIGHT

VIEW vs PRIVACY

FRESH AIR vs HUMIDITY &

POLLUTION

1

**ENERGY EFFICIENT
ARCHITECTURE**

How Energy Efficient are Malaysian Buildings?

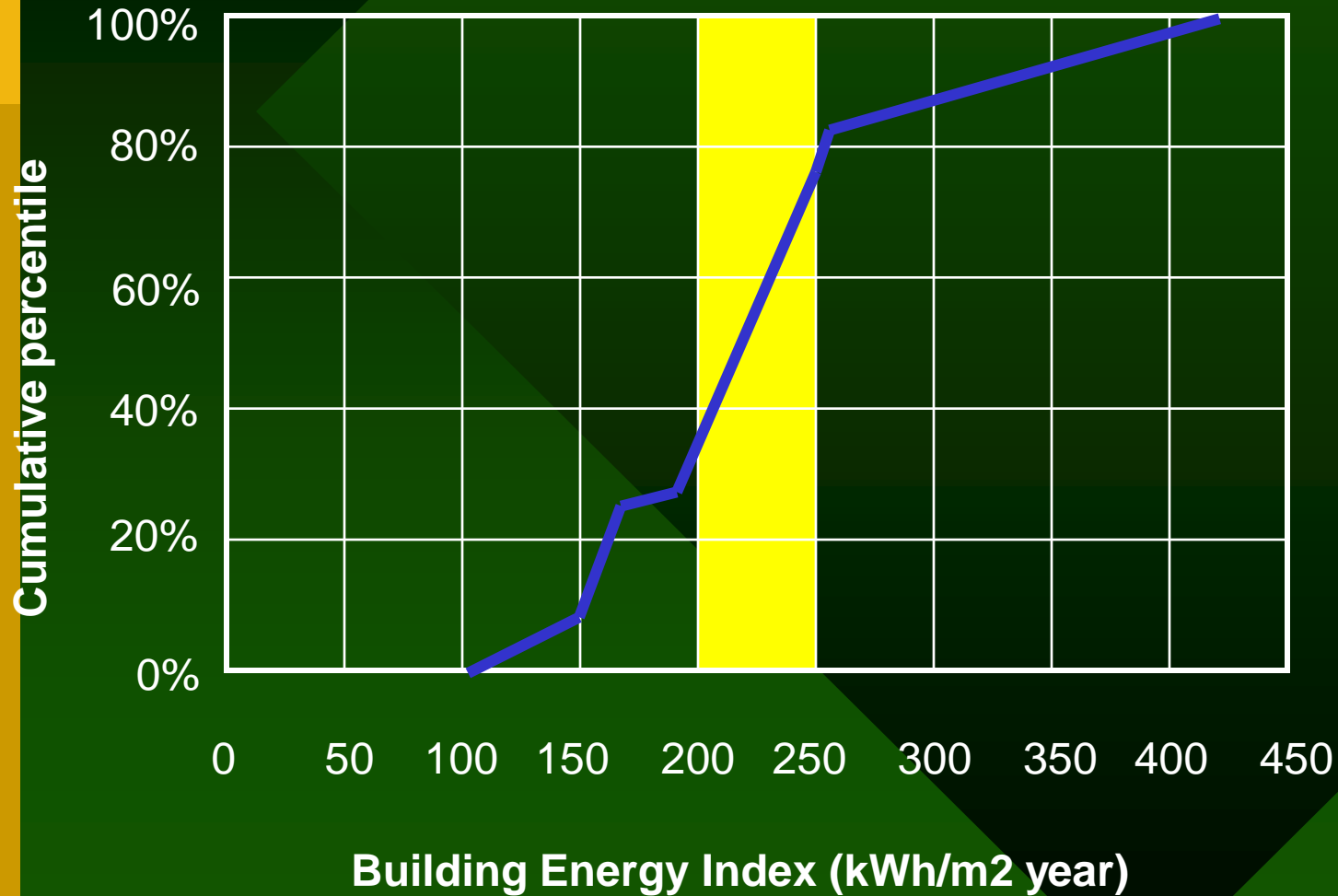

BEI of office buildings in Malaysia

Source: PTM

Where is the most Energy Used?

Novozymes Office Building Energy Load

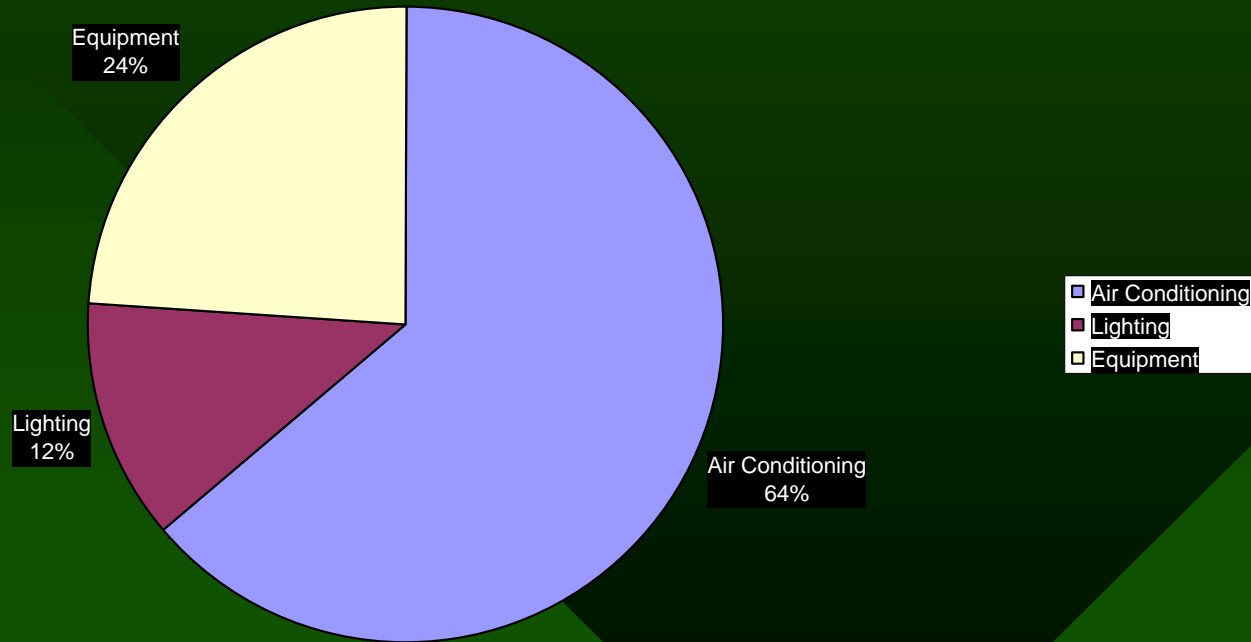

Green Building Index (Non-Residential)

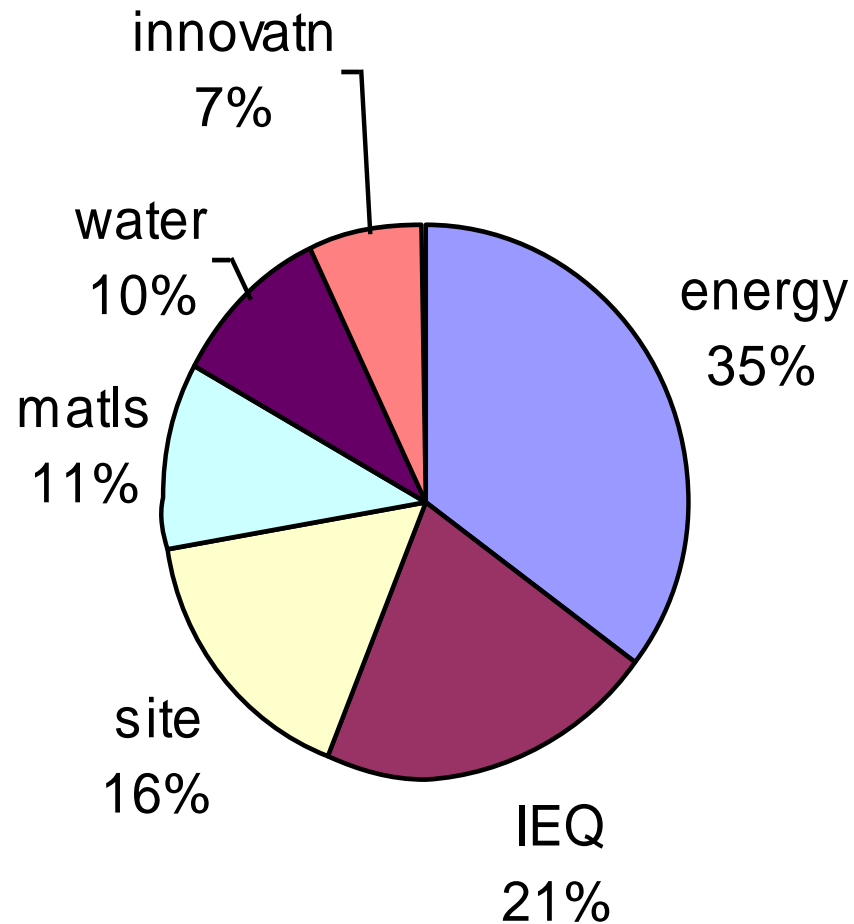

MS1525 the Cornerstone of Malaysian Energy Efficiency

MS 1525:2007

- All buildings exceeding 4,000 m² of air conditioned space shall be provided with an EMS system and
- OTTV shall not exceed 50 W/m²
- RTTV shall not exceed 25 W/m²

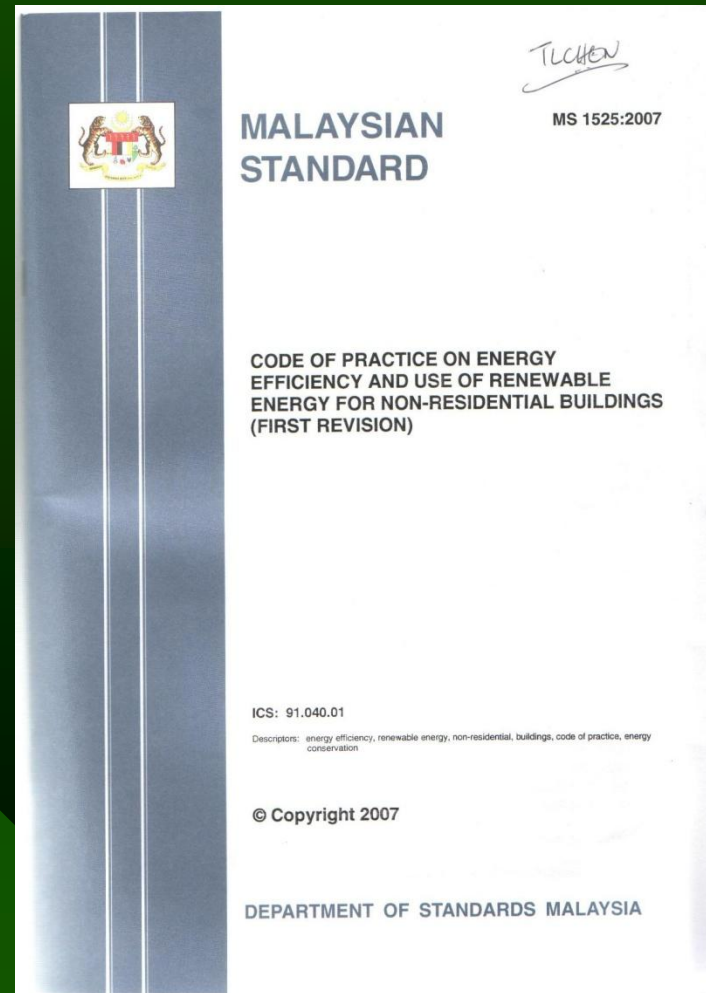

2

HEAT GAIN THROUGH WINDOWS

MS1525 key ref document

SECTION 5 : BUILDING ENVELOPE

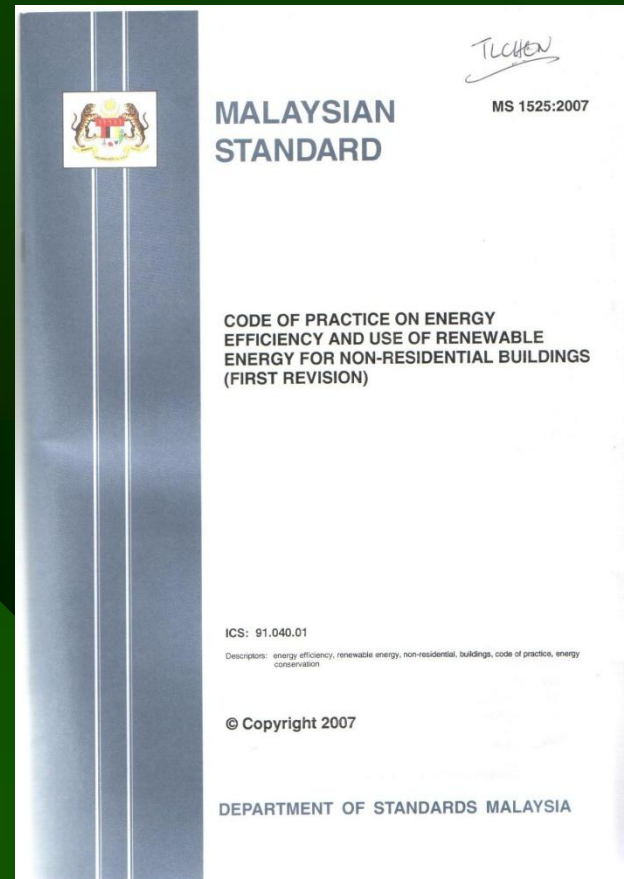

$$\text{OTTV}_i = 15\alpha(1-\text{WWR})U_w + 6(\text{WWR})U_f + 194 \times C_F \times \text{WWR} \times \text{SC}$$

Heat
Conduction
through Walls

Heat
Conduction
through
Windows

Solar Heat
Gain
through
Windows

$$\text{OTTV} < 50 \text{ W/m}^2$$

Let the **MAXIMUM DAYLIGHT** in
Block out the **SOLAR HEAT GAIN**
by maximizing the
SHADING COEFFICIENT

WINDOW EXTERNAL SHADING

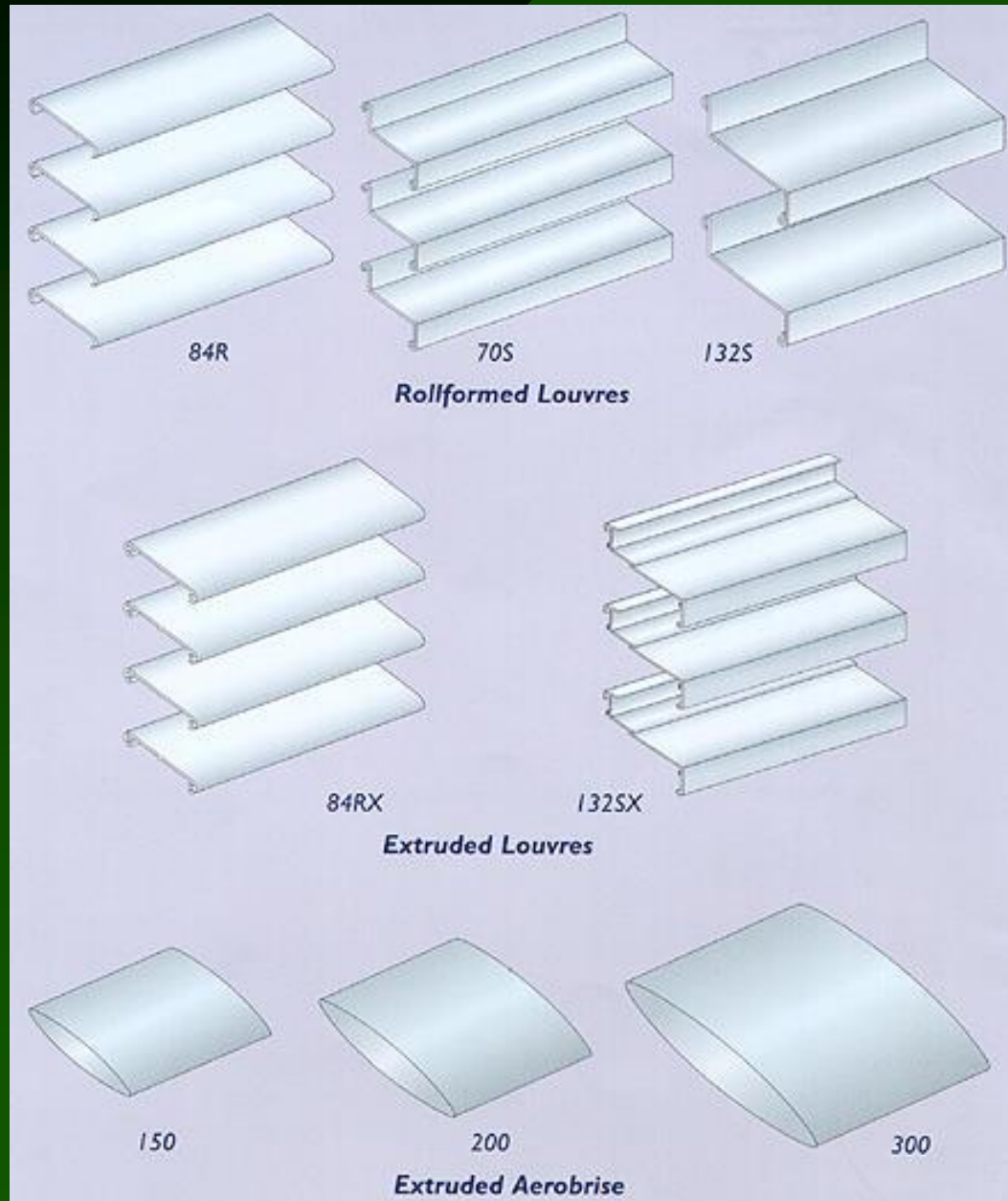

WINDOW SHADING

- External Shading Devices are more effective than Internal Blinds.
- Only need to block out Direct Sunlight.



HORIZONTAL LOUVERS FOR N-S FACING WINDOWS



VERTICAL LOUVERS FOR E-W FACING WINDOWS

IMPROVING THE SHADING COEFFICIENT OF WINDOWS

Window SC = Glass SC x Shading Device SC

$$\text{SC}_{\text{window}} = 0.6 \times 0.8 = 0.48$$

a reduction of more than 50%

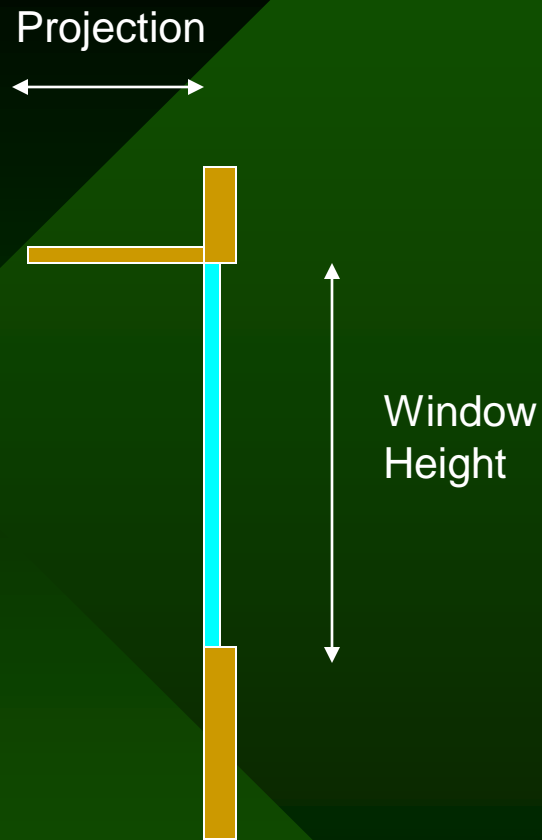

$R1 = \text{Projection} / \text{Window Height}$

Typical = $0.3\text{m} / 1.2\text{m} = 0.25$

SC = 0.8

TABLE 5

HORIZONTAL PROJECTION SHADING COEFFICIENTS

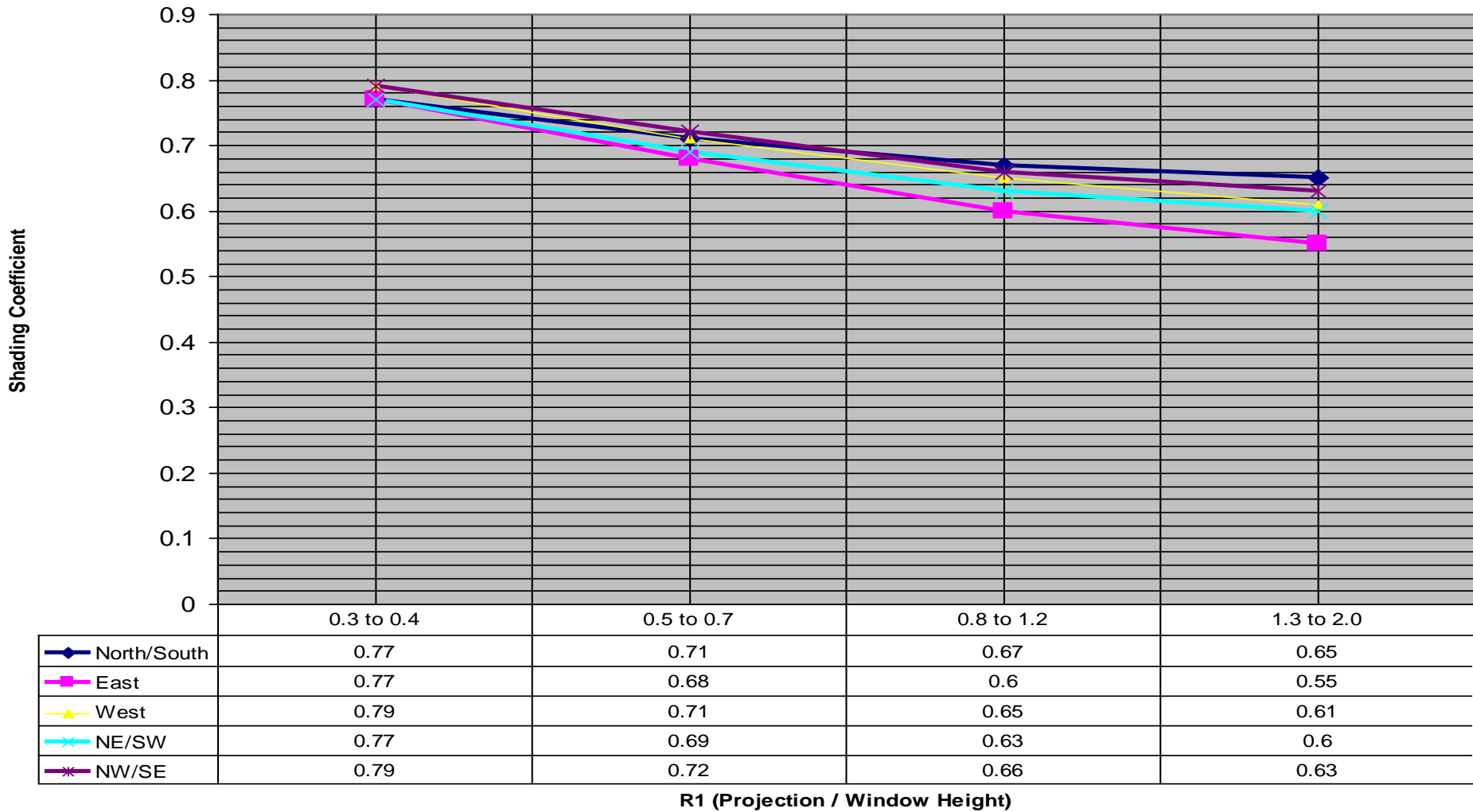

R1 (Projection / Window Height)

TABLE 6

VERTICAL PROJECTIONS SHADING COEFFICIENTS

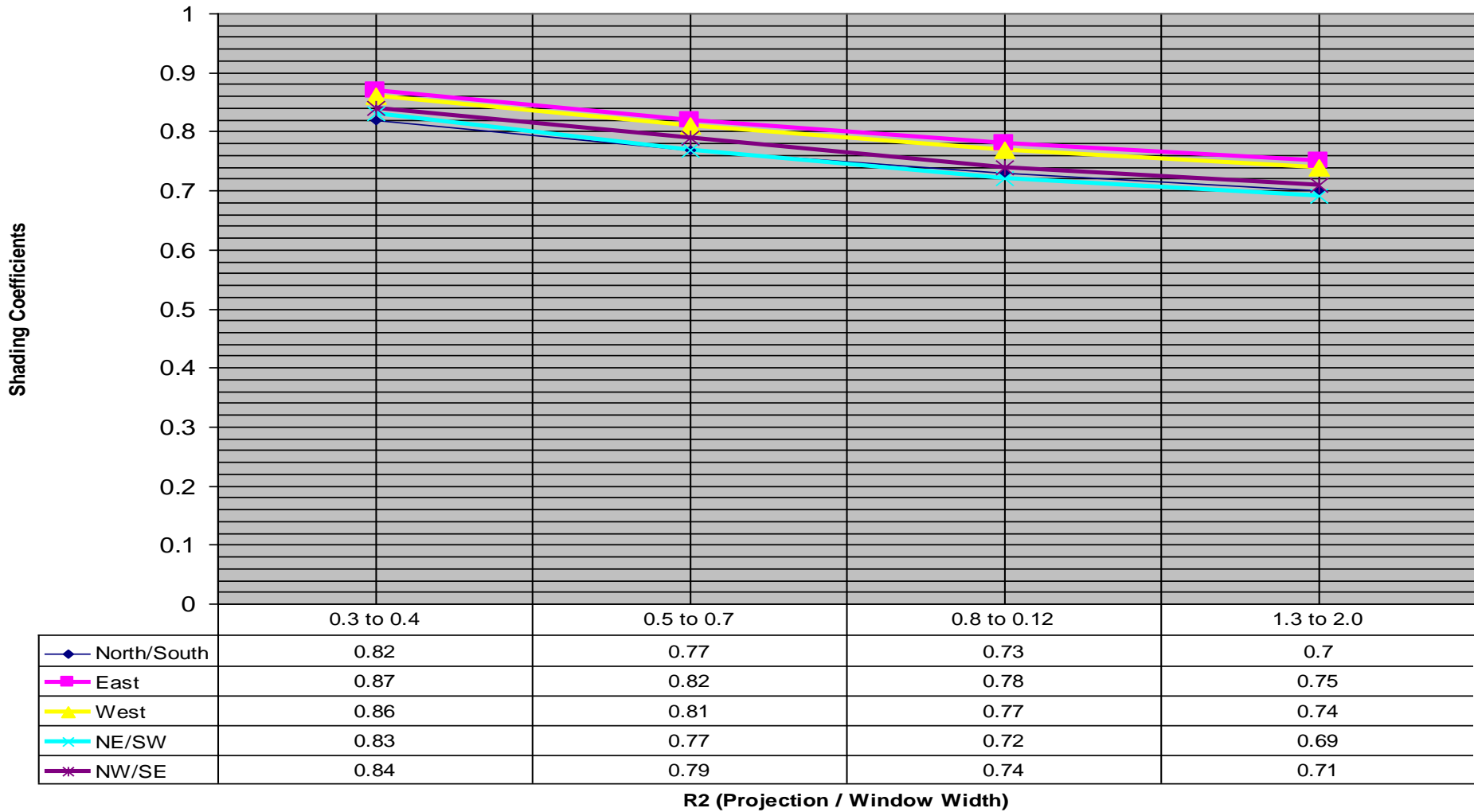

R2 (Projection / Window Width)

3

DAYLIGHTING ESSENTIALS

Illuminance (Brightness)

Lux level

- Measure in Lux level or daylight factor (DF)

Daylight Factor

- A measure of light quantity indoor based on available light outside.
- **Daylight Factors** are provided via overcast sky conditions.

$$DF = \frac{E_{\text{internal}}}{E_{\text{external}}} \times 100\%$$

Perceived Illuminance

Under overcast sky conditions, subjective responses to daylight factors are as follows.

- With a **DF <1%** a room will seem gloomy. Electric lighting may be required.
- With a **DF between 1% to 3%**, a room will feel it is day lit, although supplementary electric lighting may be needed for fine work
- With a **DF >3%**, a room will feel vigorously day lit. No electric lighting will be needed.

• **NOTE** : External illuminance over Malaysian skies ranges from 12,000 lux to 20,000 lux.

- **1% DF = 120 to 200 lux**
- **2% DF = 240 to 400 lux**
- **3% DF = 360 to 600 lux**

Daylight Estimation Using Split Flux Method

The most usable manual method for calculating Daylight Factors is the split flux method. This is based on the assumption that, ignoring direct sunlight, natural light reaches a point inside a building in three ways:

Sky Component (SC)

Directly from the sky, through an opening such as a window.

Externally Reflected Component (ERC)

Light reflected off the ground, trees or other buildings.

Reflected Component (IRC)

The inter-reflection of (SC) and (ERC) off other surfaces within the room.

Daylight Estimation Using Split Flux Method

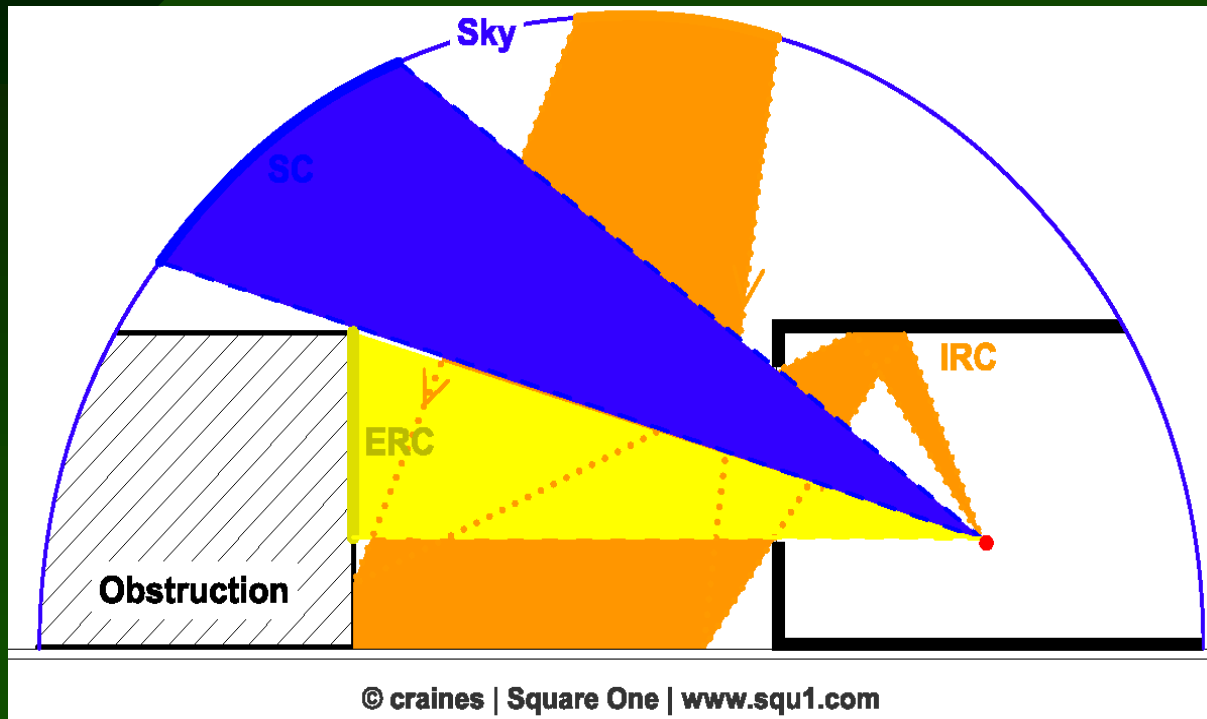

$$DF = SC + ERC + IRC$$

Daylight Estimation Basics 1

1. Window height

Depth of daylight penetration depends primarily on the window height. Rule of thumb 1 Max depth = 2.5 window height

2. Window Area

Rule of thumb 2 for daylight factor of average 2%, area of window required is 10% of floor area

3. Check with following charts for various DF options and if there are external obstructions

4. Use Daylight uniformity chart to re-check daylight penetration depth

UBBL Requirements

Bylaw 39(1)

- Every room designed for residential, business or other purposes except hospitals & schools shall be provided with natural lighting and natural ventilation by means of one or more windows having **total area not less than 10% of the floor area** and shall have opening for uninterrupted air passage of 5%
- = DF 2% = 240 to 400 lux

Bylaw 39(2)

- **Hospitals window area 15%** and open able windows 10%
- = DF 3% = 360 to 600 lux

Bylaw 39(2)

- **Schools window area 20%** and open able windows 10%
- = DF 4% = 480 to 800 lux

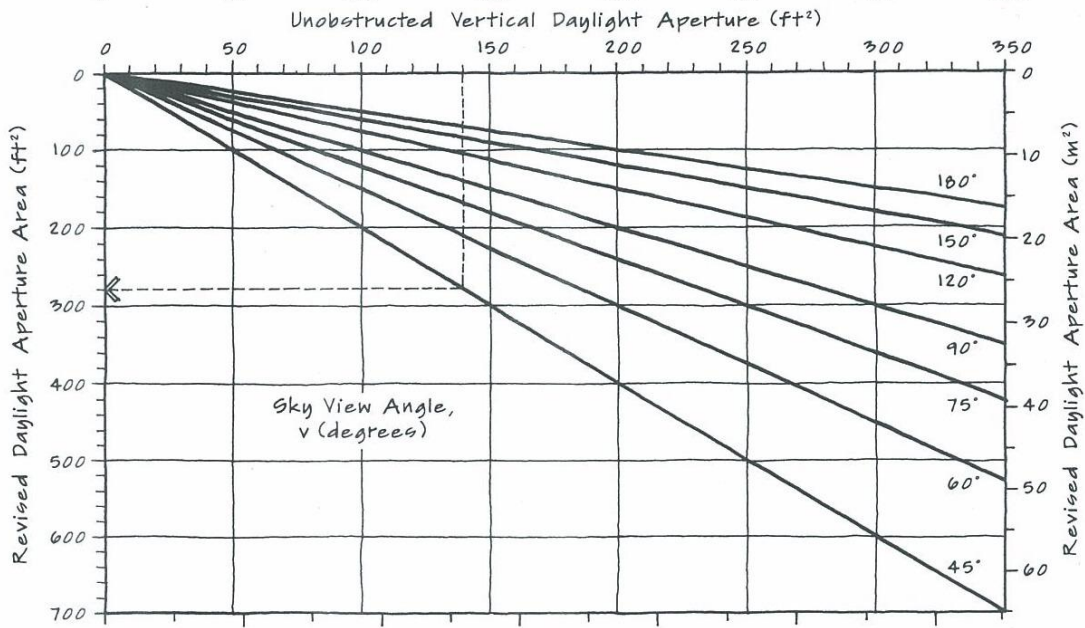
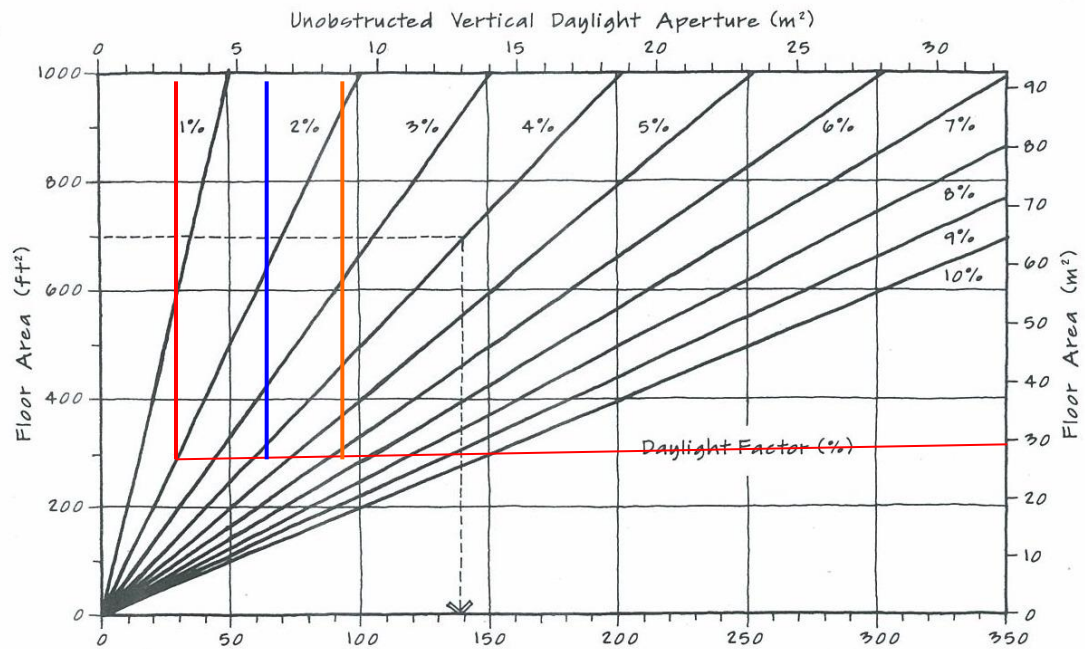

Sizing Windows for Daylighting

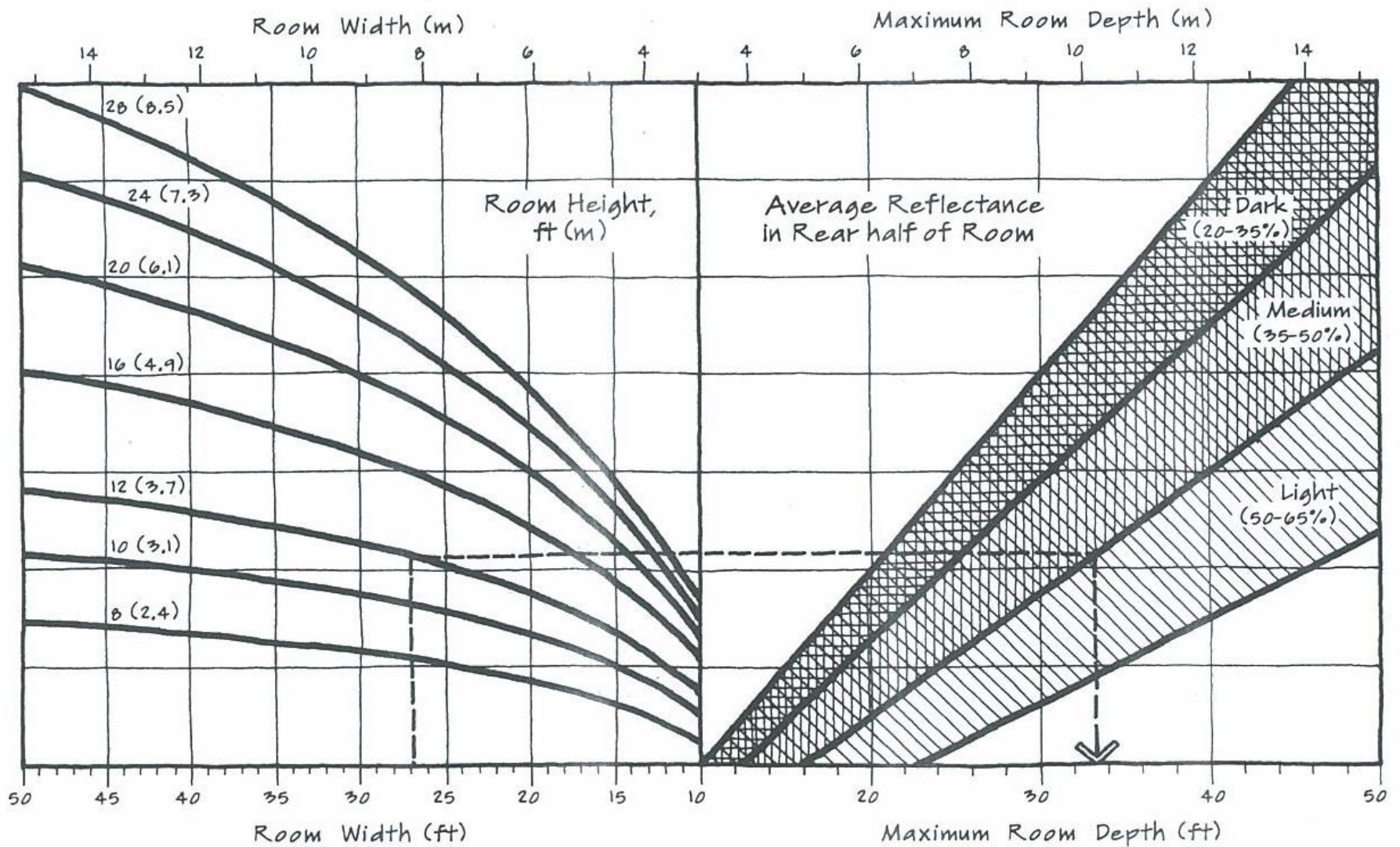

Estimating Maximum Room Depth for Daylight Uniformity

DF simulation using IES

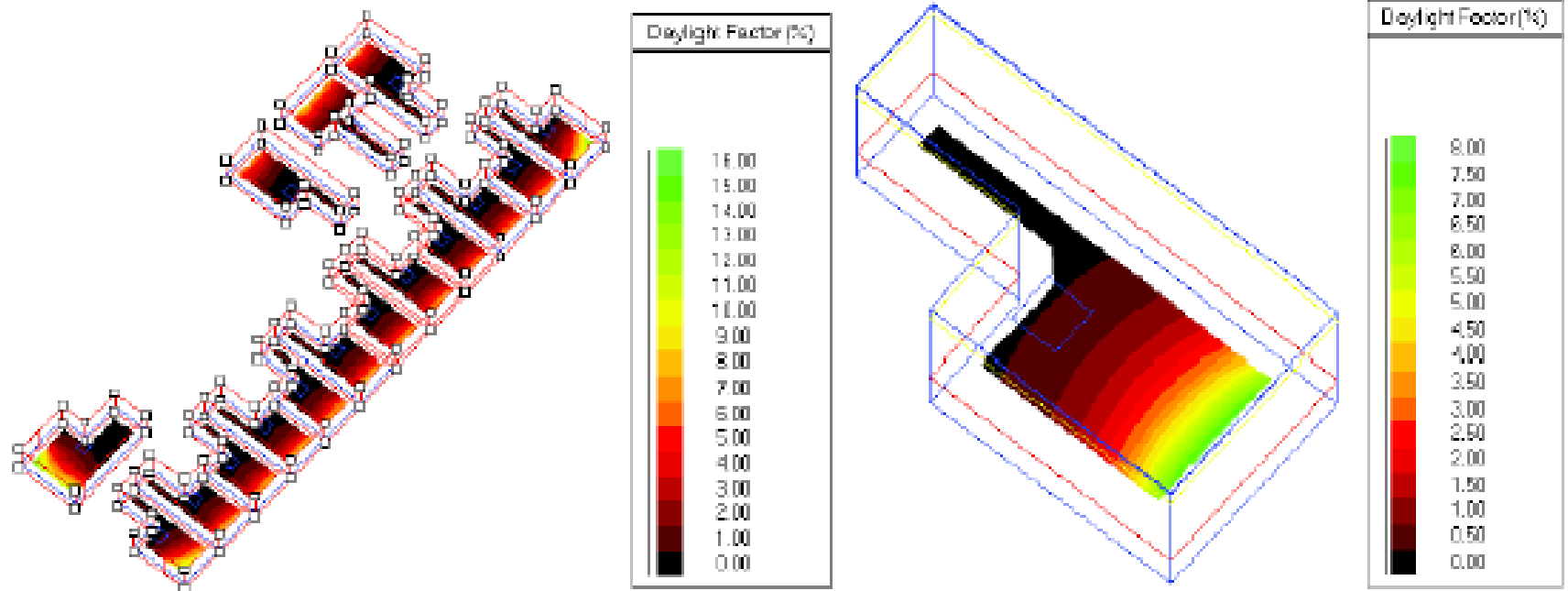

% NLA > 1% Day Lighting Factor at a working plane of 800mm:

70%

AFTER AIR CONDITIONING LIGHTING ENERGY CONSUMPTION IS THE NEXT MOST IMPORTANT FOR COMMERCIAL BUILDINGS.

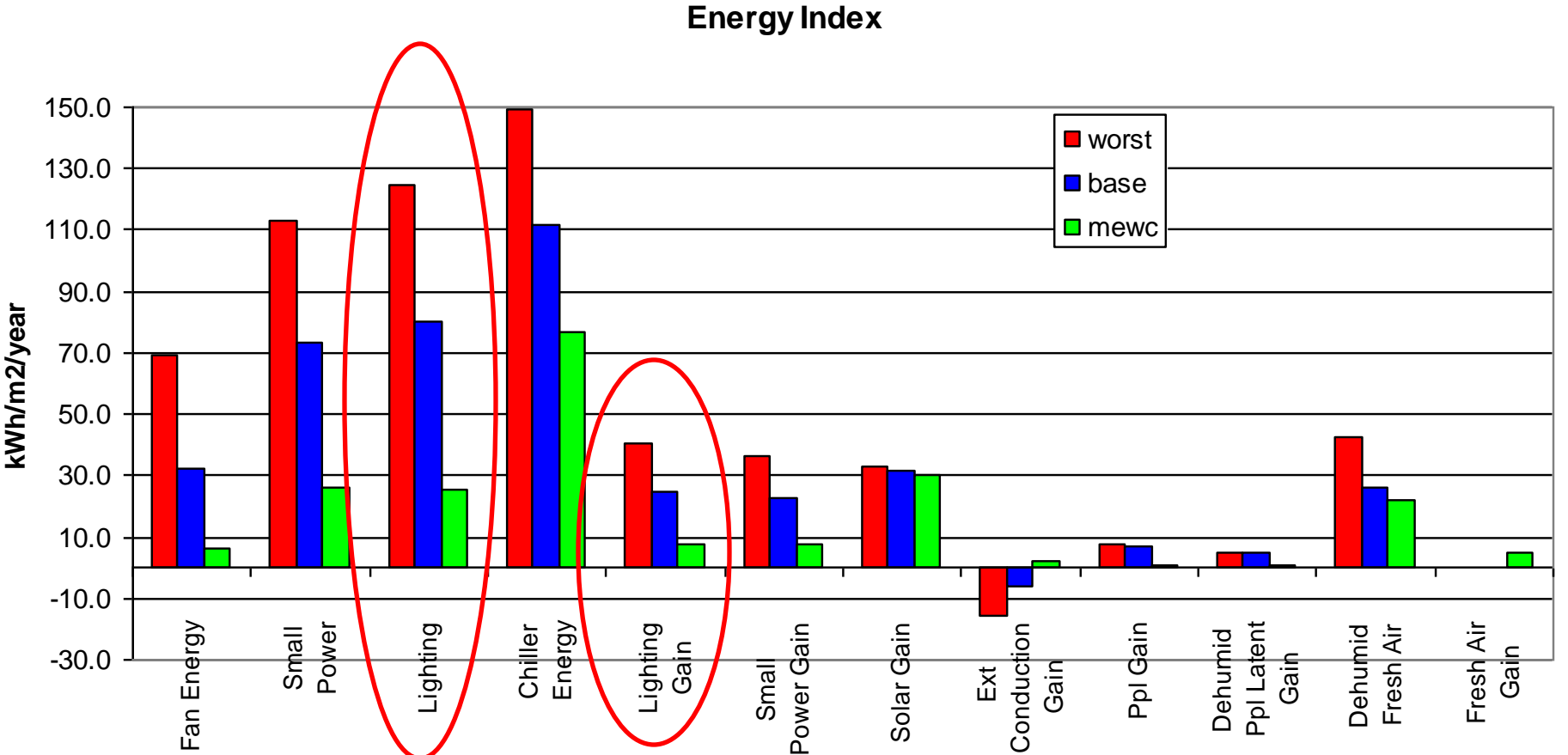

WINDOWS & DAYLIGHTING IN BUILDINGS

- Daylight in Building offset electrical lighting load
- Electrical lights produces more heat than Diffused Daylight
- Zone electrical lighting system correctly

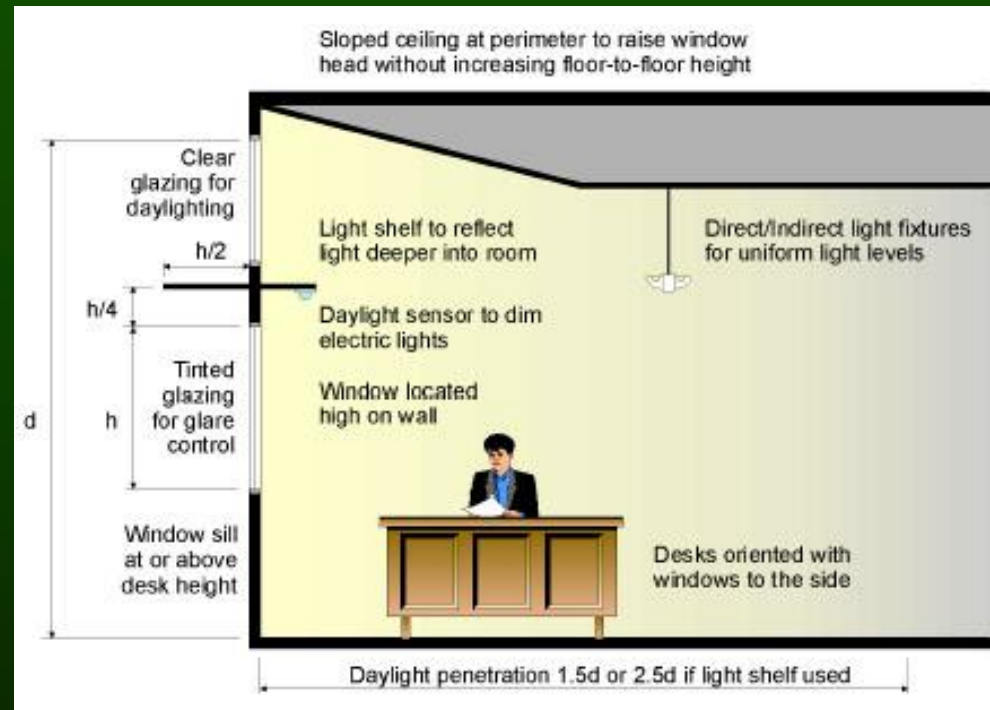

DAYLIGHTING ESSENTIALS

1. Bring the light in high, above the view plane
2. Diffuse sunlight inside the space. Don't allow beam sunlight to strike work surfaces.
3. Use only north and south vertical windows
4. Choose the glazing carefully.

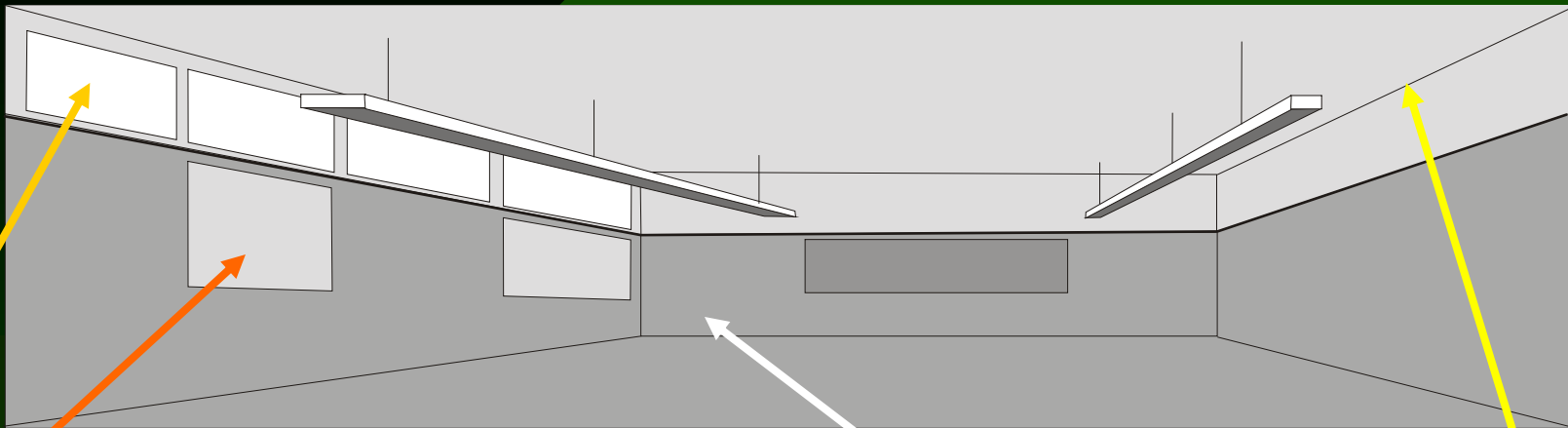

- Continuous strip of narrow windows up high
- A few view windows. These have a low visible transmittance (0.2 – 0.3), to balance the luminance of the walls with the luminance of the outdoor view. Every work place in the building should have a visual connection to the outside
- Eggshell white color in the upper part of the room to bounce the light across the room
- Mid-to-light colors in the lower part of the room

Effect of Window design on daylight distribution

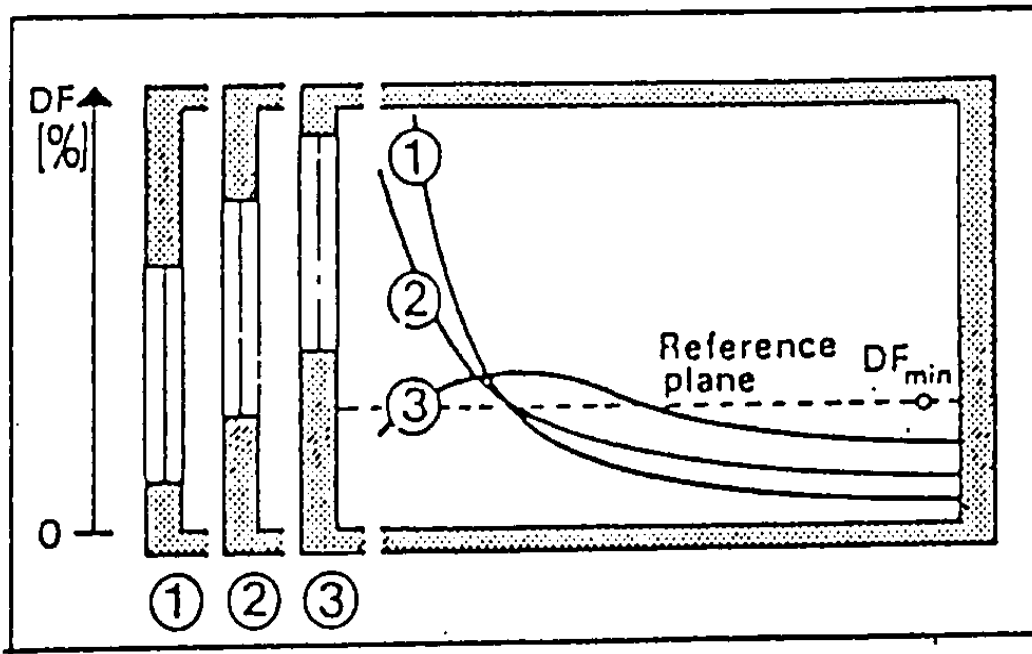

Max daylight penetration = $2.5 \times$ Window Height

PSALI Permanent Supp Artificial Lighting

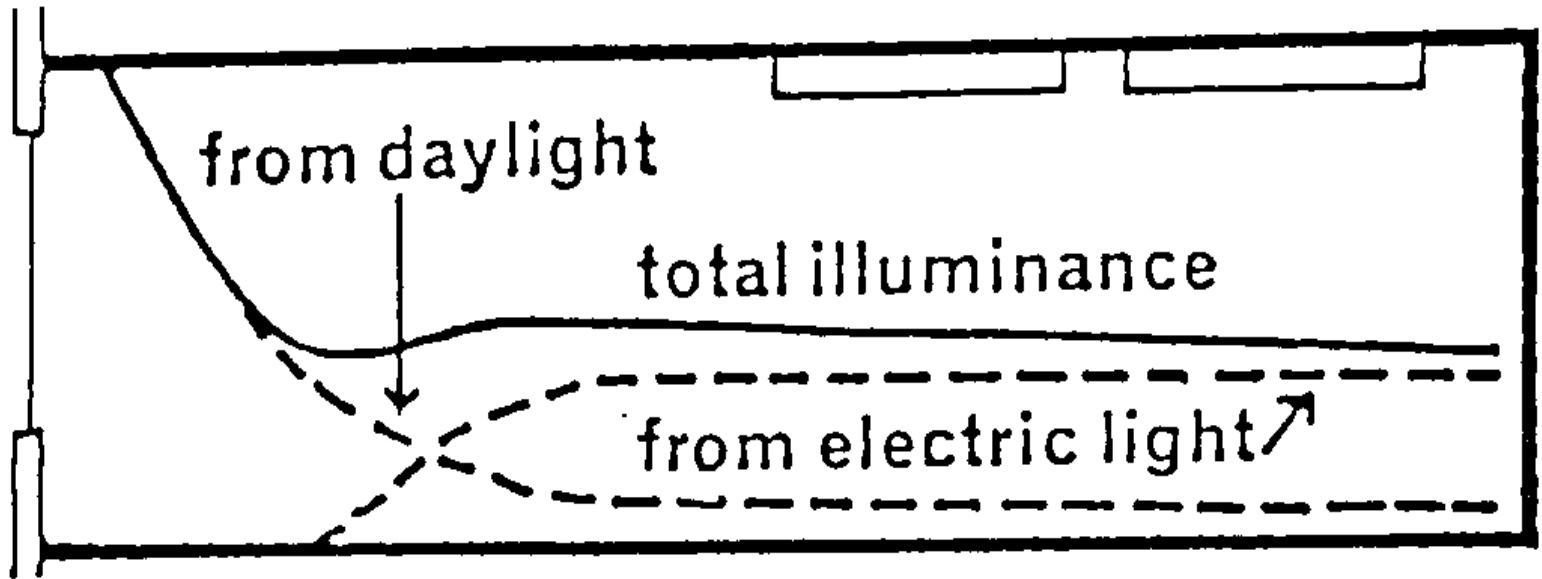

PSALI

For Office of home task lighting, perimeter lighting can employ the **Permanent Supplementary Artificially Lighting of the Interior** procedure.

1. Determine the perimeter spaces with **DF more than 3%**. These spaces will have adequate lighting for at least **80% of daylight hours**.
2. This is usually up to 3 meters from the perimeter walls. Put in a separate switching for the lights.
3. Determine the spaces with **DF more than 1%**. Have half the light fittings on one switch and the other half at alternate intervals on another switch.
4. The second half of the lights need only be **switched on for 50% of the time**, giving a saving of 25% for this second band.
5. For office spaces with depth of about 3x window height and 3 bands of light switches, **potential energy savings from daylight is 24%+7%=31%**

PSALI

> 300 lux (from diffuse radiation)

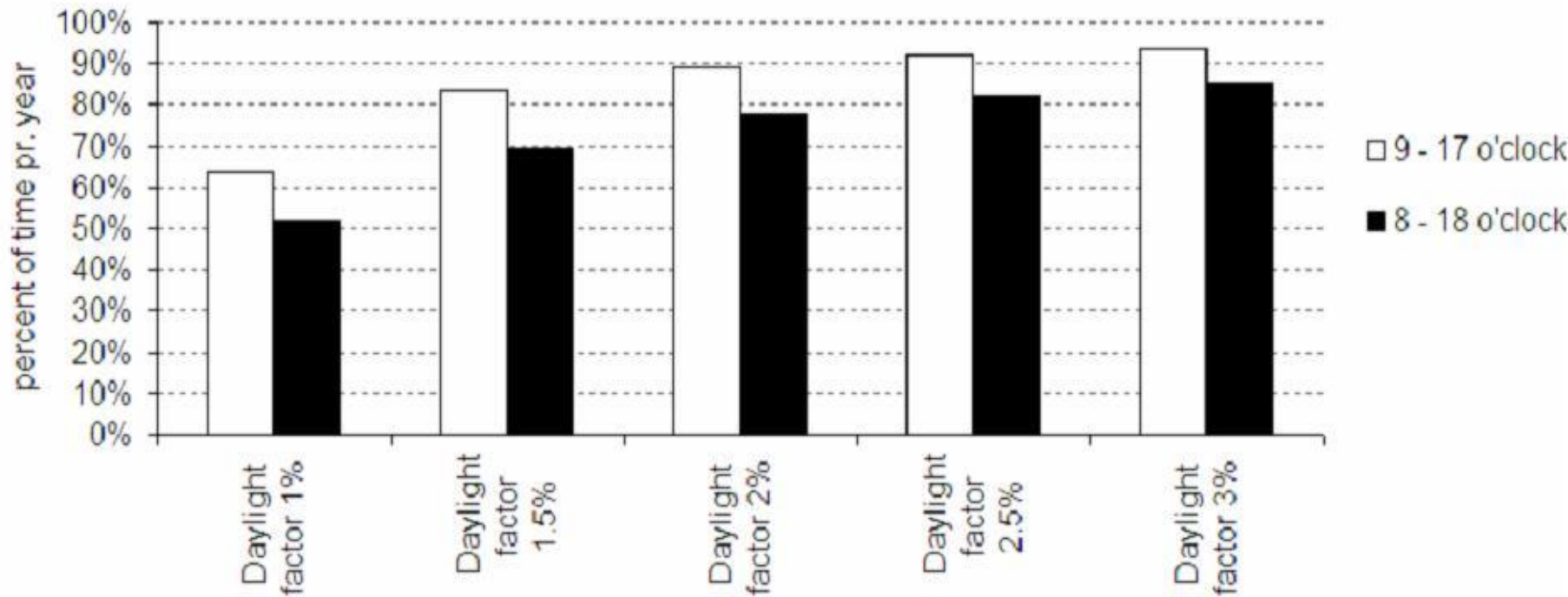

“Tropical Daylighting” (Reimann, Kristensen, Tang)
IEN Consultants, www.ien.com.my

4

OPTIMISING THE BUILDING ENVELOPE FOR DAYLIGHT

Let the **MAXIMUM DAYLIGHT** in

By having the **highest VLT**

Block out the **SOLAR HEAT GAIN** by
maximizing the

SHADING COEFFICIENT=Lowest SC

CHOOSE SPECTRALLY SELECTIVE GLAZING

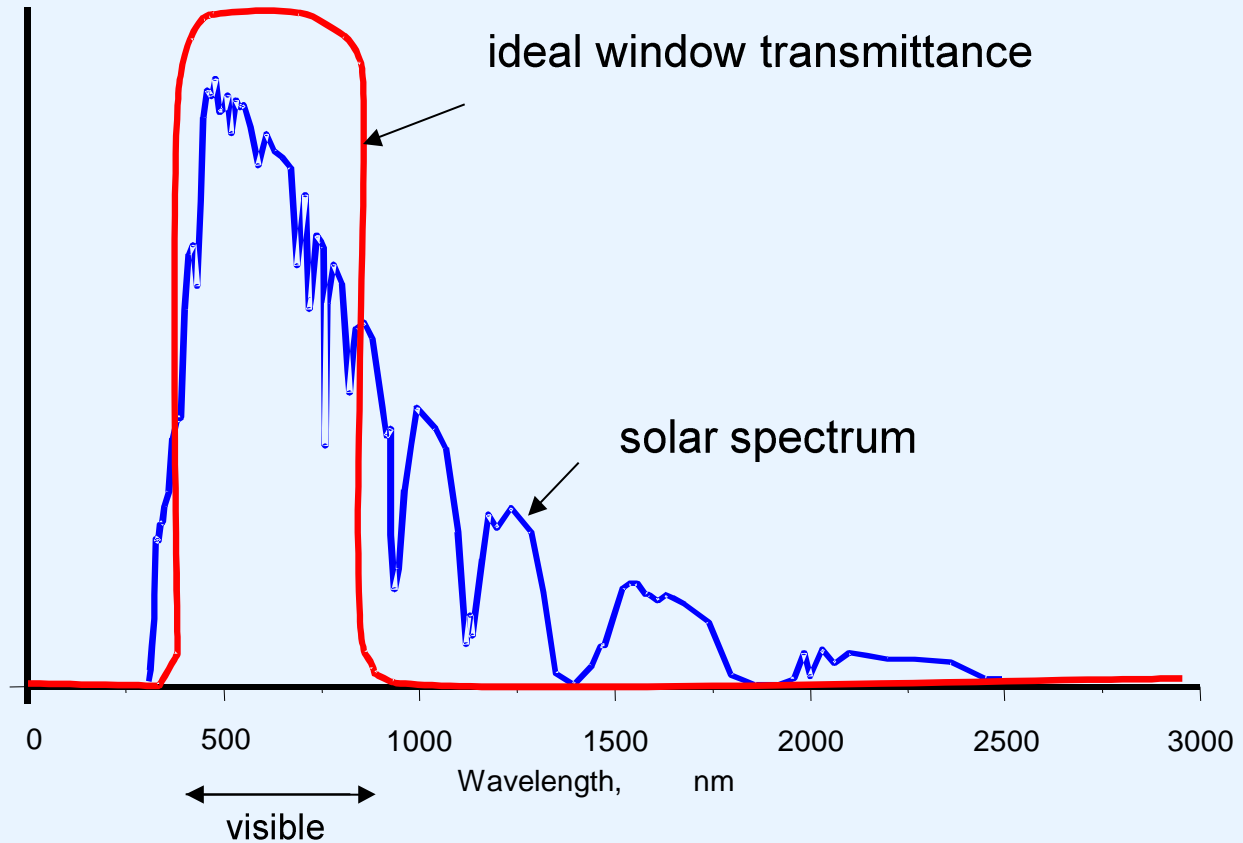

WINDOW GLAZING

Spectrally Selective Glazing :

Lets in the lights, blocks out the heat

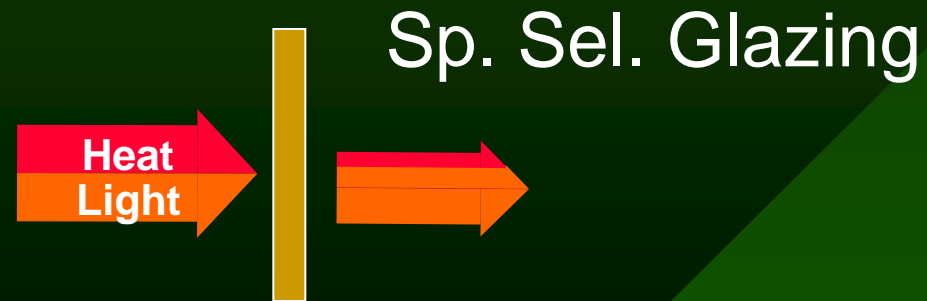
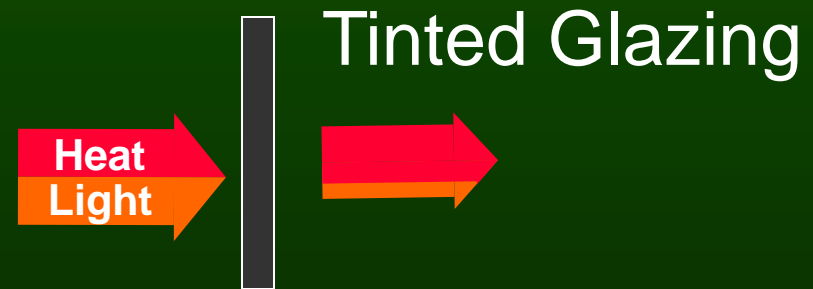
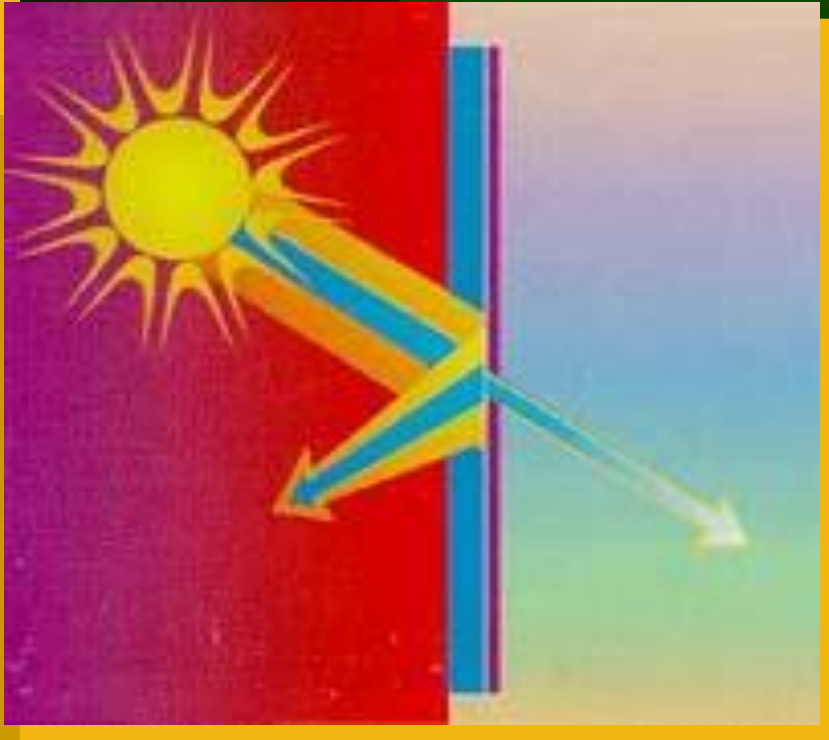

Typical Values, Double Glazing : Light 60% Transmission

Heat 30 % Transmission

OPTIMIZING VLT vs SC

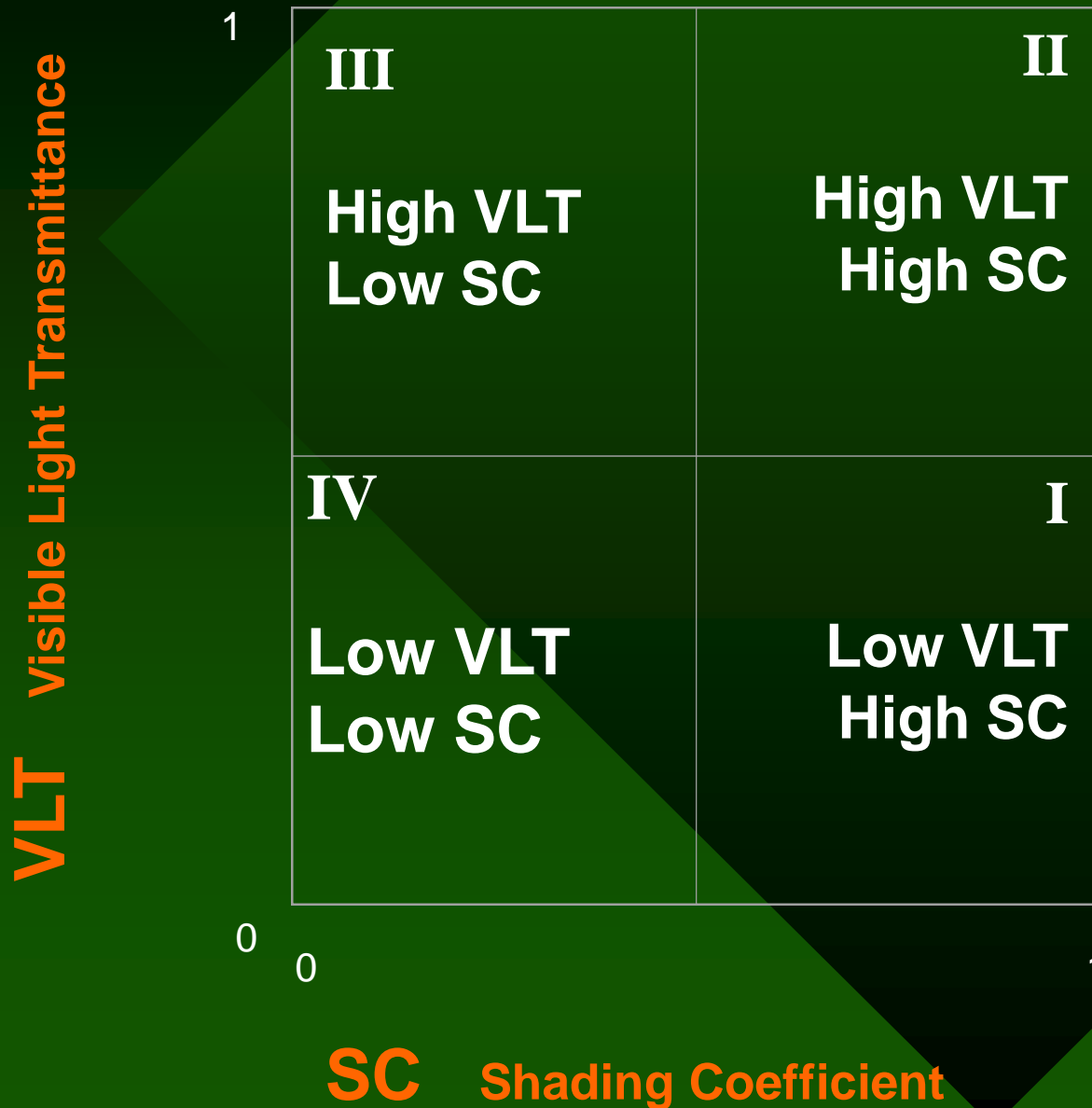

OPTIMIZING VLT vs SC

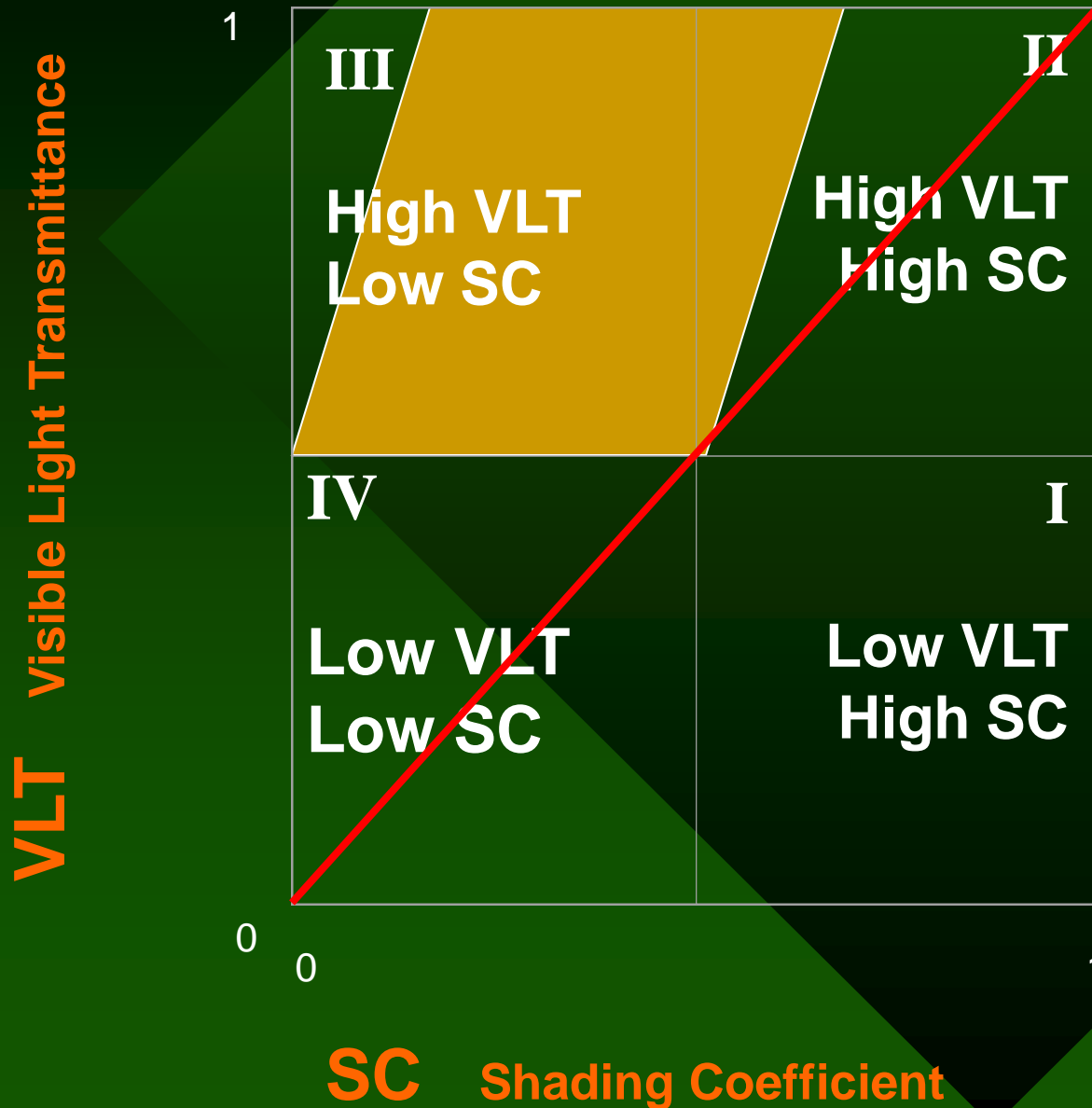

CLEAR GLASS

Clear Glass VLT vs SC

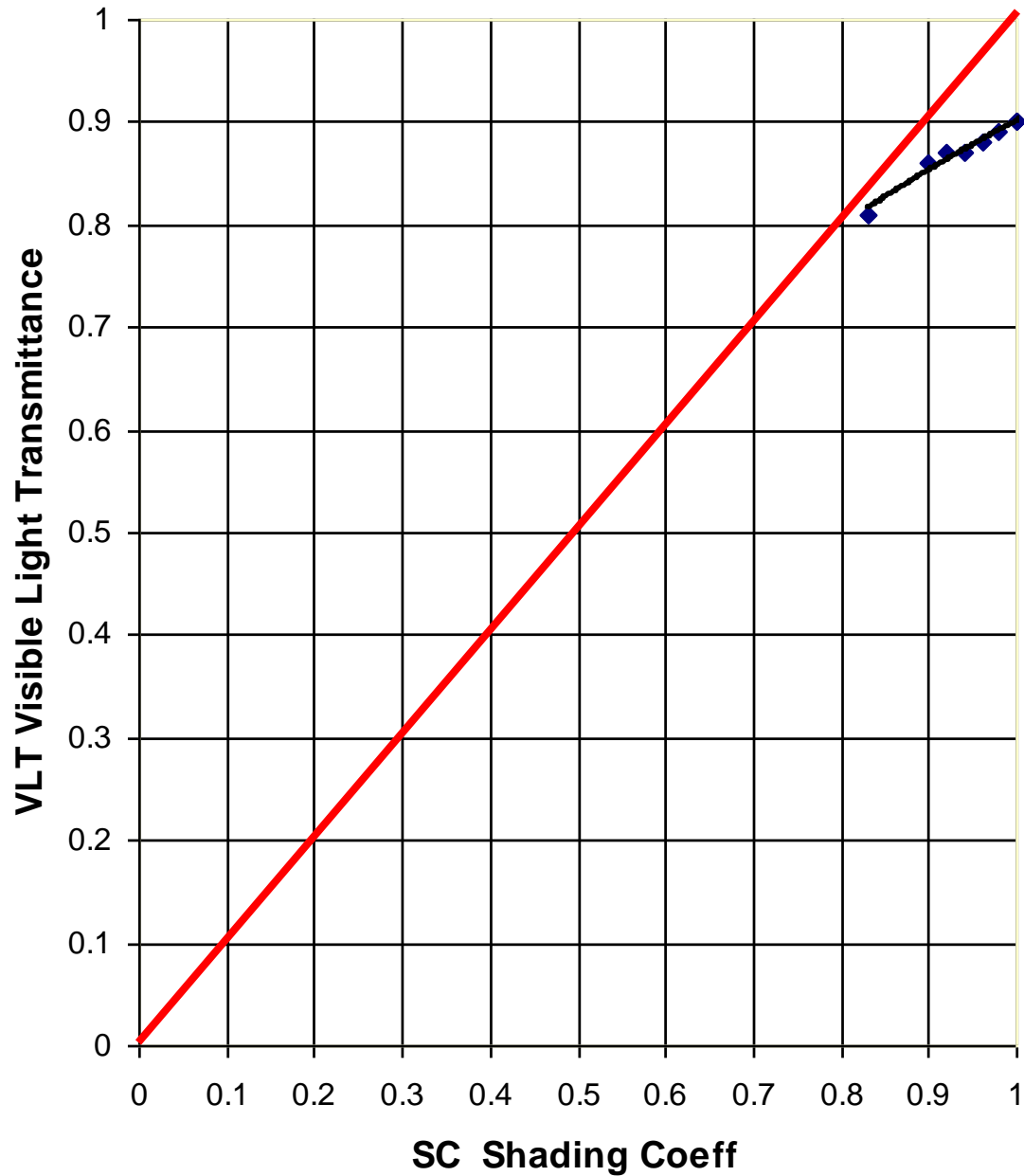

TINTED GLASS

Tinted Glass VLT vs SC

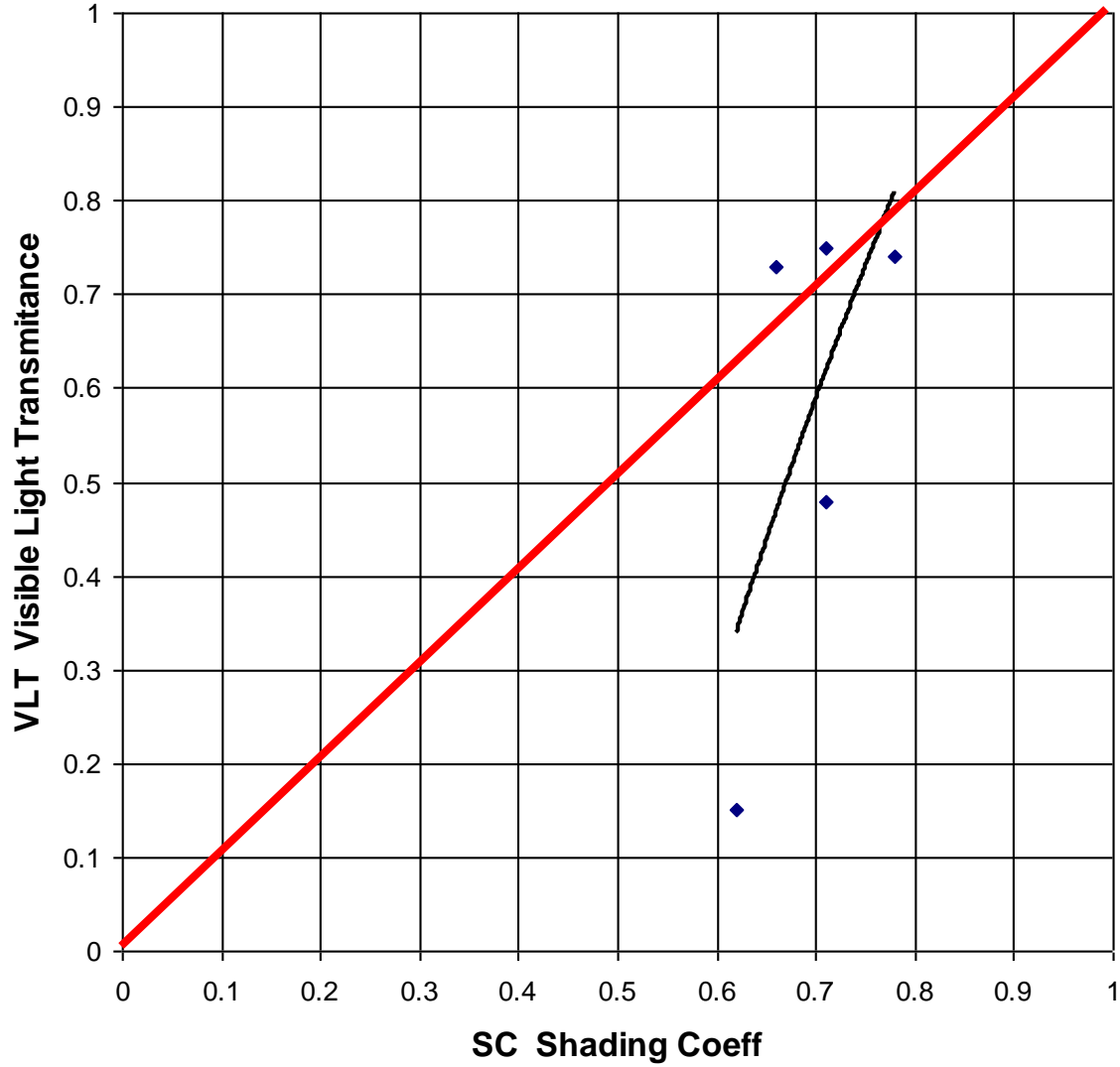

TINTED LAMINATED GLASS

TINTED LAMINATED GLASS

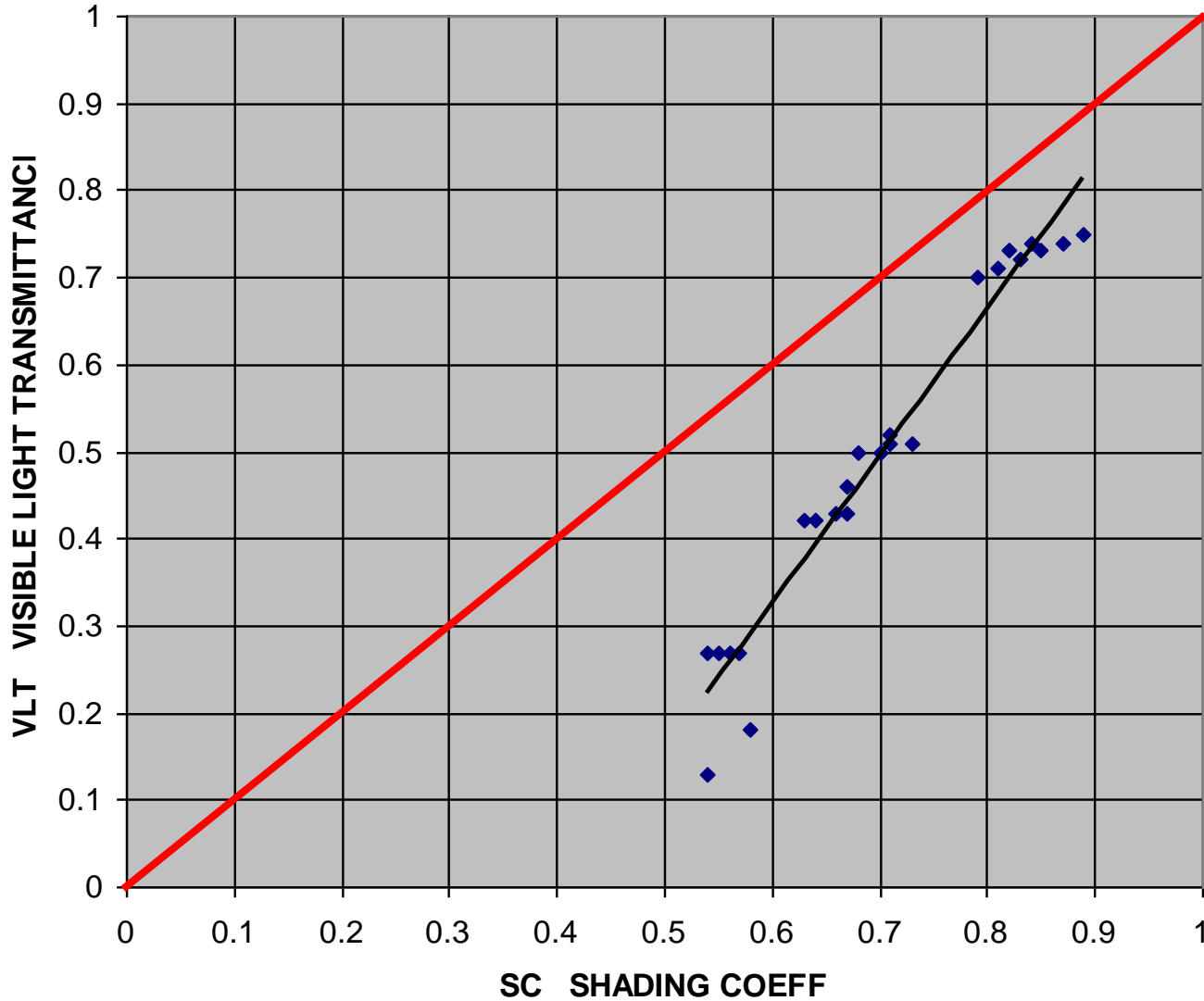

REFSHINE-S 6mm

REFSHINE-S 6mm

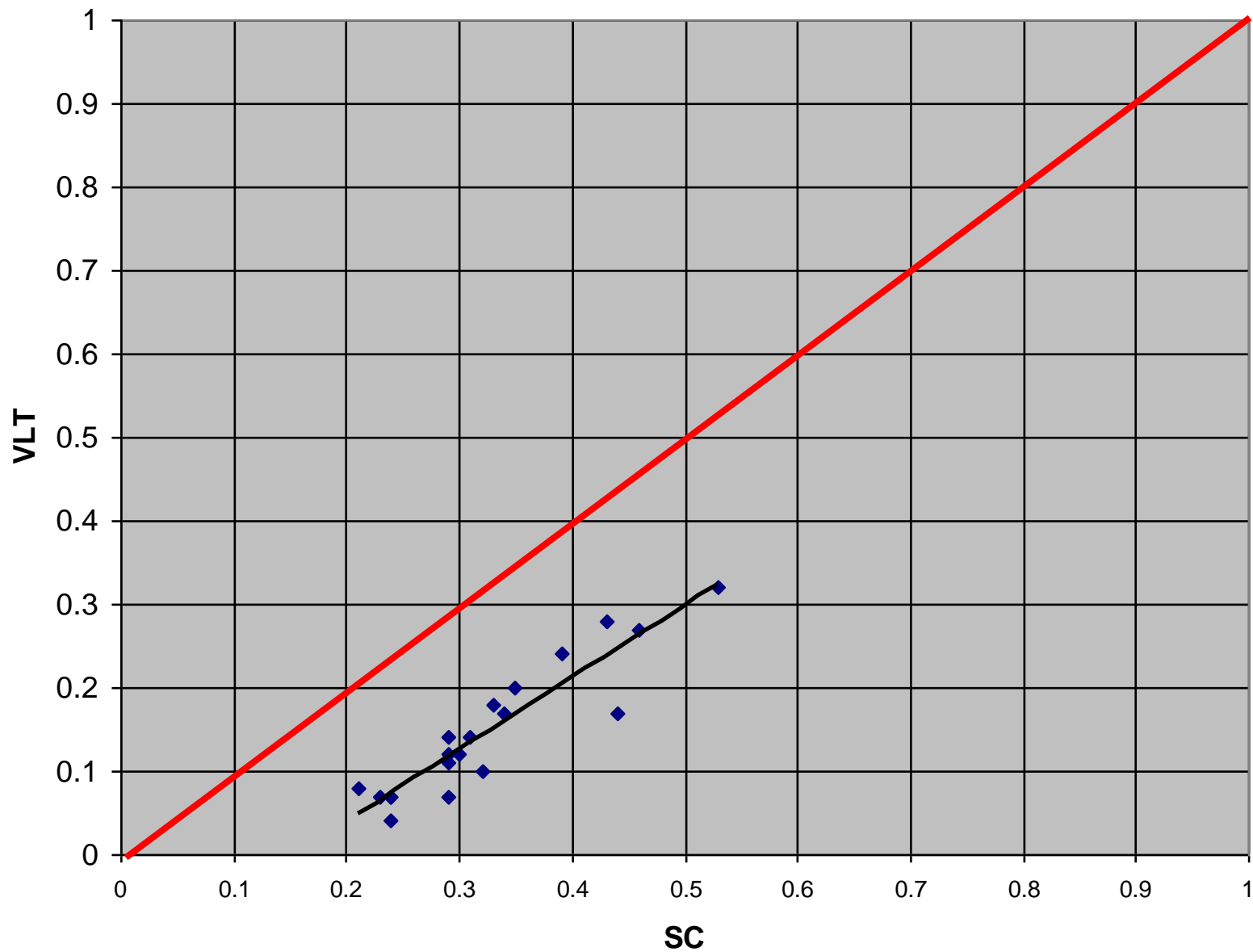

REFSHINE-S laminated

REFSHINE-S LAMINATED GLASS (6+INTERLAYER+FL3) SC vs VLT

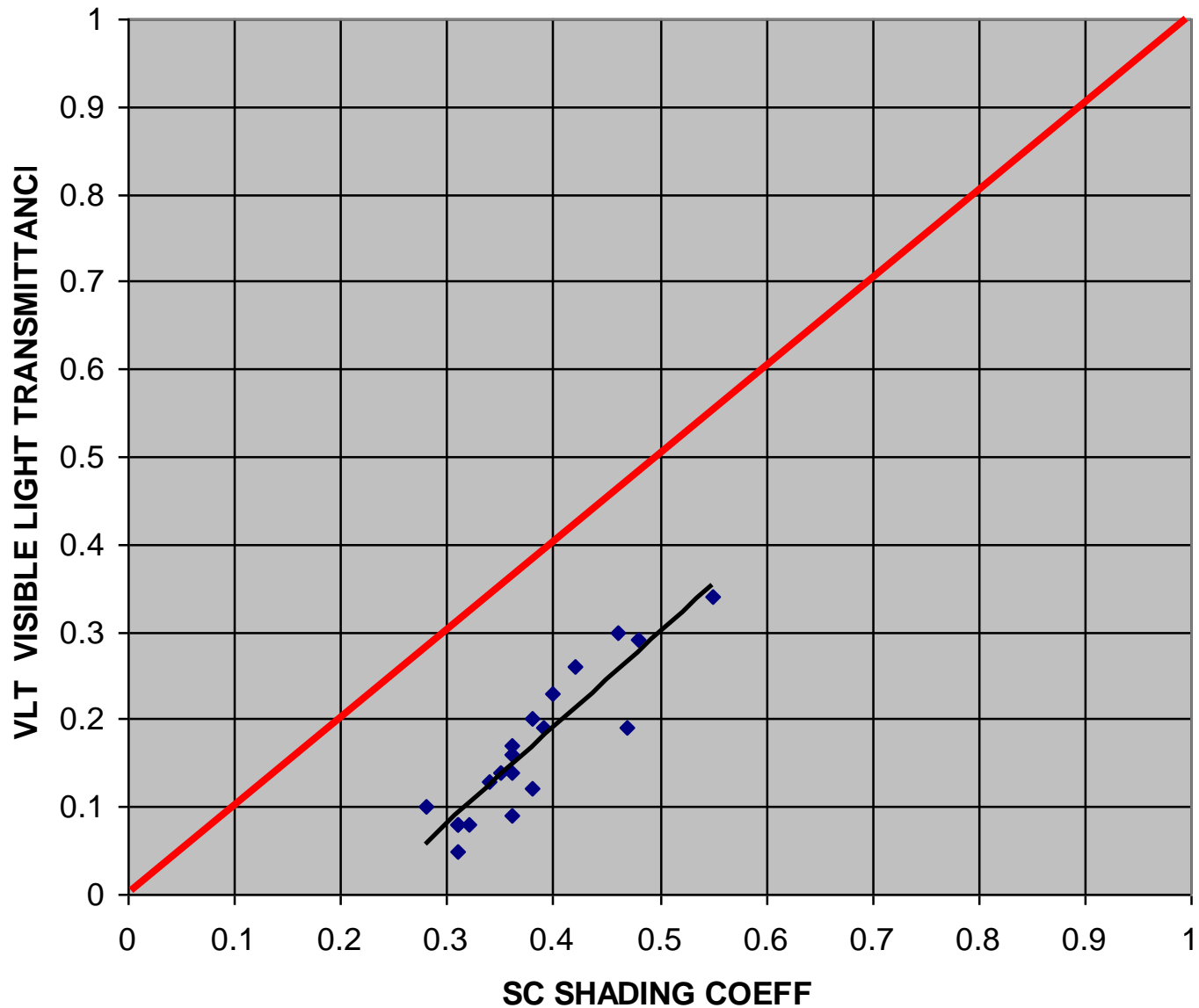

REFSHINE-S DGU

REFRESHINE-S DGU SC vs VLT

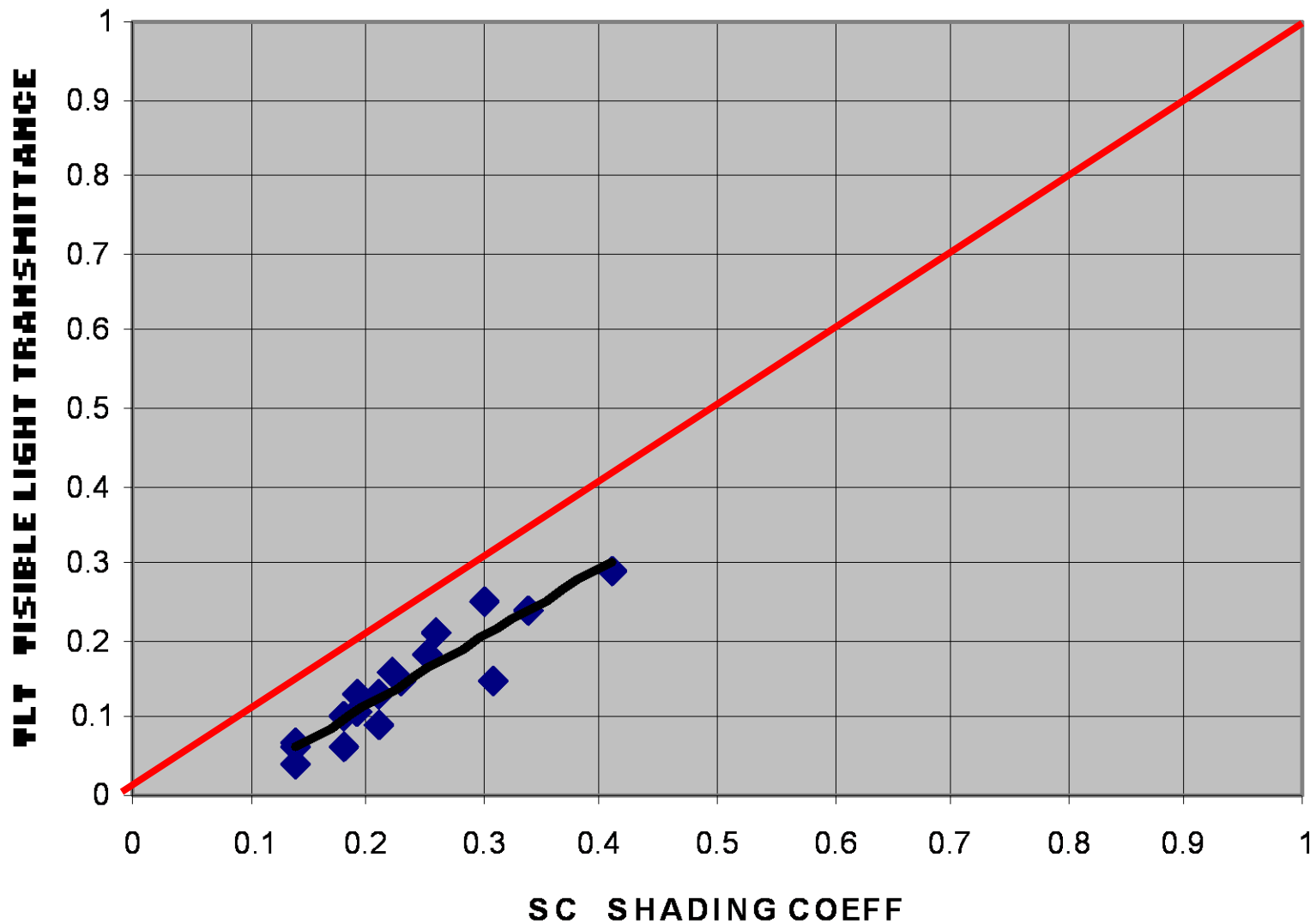

THANK YOU

csa@arkitekads.com

info@mgbc.org.my

